

NEW



# BeeWrap<sup>+</sup>

Pre-Stretch >>>> Productivity >>>> Robustness >>>>

## DATASHEET

SAFE • STRONG • SIMPLE

### Semi-Automatic Robot Stretch-Wrapper

BeeWrap+ is a mobile wrapping machine used for palletizing goods with stretch film. It is suitable for heavy weight items, unusual shapes, and loads with large dimensions. It is equipped with a digital control panel that allows the user, in an easy and functional way, to alter various parameters and set-up customized wrapping cycle programs.

With sleek design modifications the newly upgraded features the BeeWrap+ is also equipped with new **AGM dry battery technology**. This guarantees a higher working autonomy (optional up to **400 cycles per charge**) and enhances safety within the machine!

### KEY FEATURES

- ✓ **Energy saving** – Automatic shutdown of the machine after 10 minutes of inactivity
- ✓ **Safety First** – Thanks to the new AGM dry battery technology there is no danger related to battery maintenance and acid leaks
- ✓ **Extensive battery duration** – Up to 250 cycles with each battery charge (Optional up to 400 cycles)
- ✓ **Easier to transport** – Thanks to the AGM technology, batteries are not subject to any transport restrictions
- ✓ **Extensive safety** – BeeWrap incorporates several safety features as standard
- ✓ **Increased production capacity** – Thanks to customized settings
- ✓ **Versatile use** – Suitable for very large and round loads
- ✓ **Flexibility** – Machine is easily moved to various locations
- ✓ **Modular system** – Meeting your individual needs
- ✓ **Easy-to-use** – Due to the simple control concept
- ✓ **CE compliant** - Engineered and produced in Italy according to EU safety standards

### DIMENSIONS

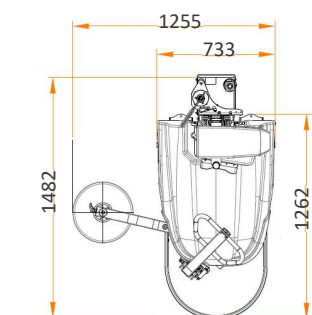

Version BeeWrap<sup>+</sup> – L – M

Depending on version, equipment and options, the machine dimensions may differ.

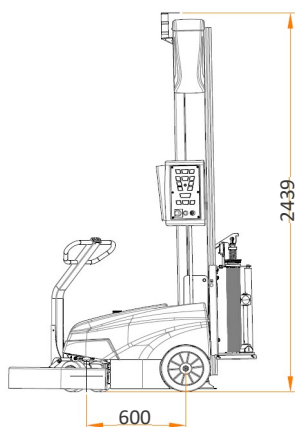
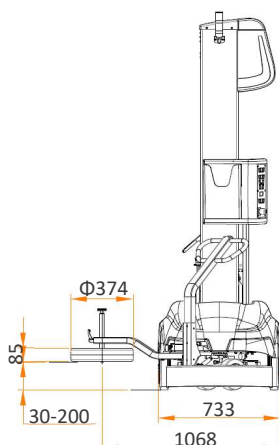

## DATASHEET

Carriage type	LP	FM	M
Description	Powered Pre-Stretch	Electro-Magnetic Brake	Mechanical Brake incl. quick release
Pre-Stretch level (%)	240 / 200 / 150	-	-
Max. pallet height (mm) incl. overlap above pallet top edge	2.100 std. (Low) / 2.600 (Medium)		
Pallet size (mm)	min. 400 x 500 / max. 6.000 x 7.000		
Min. pallet weight (kg)	20 – 55 (depending on film tension and friction)		
Power supply	100 – 240 V (via on-board charger)		
Rotation speed (m/min)	50 – 80 (adjustable)		
Up & Down Carriage speed (m/min)	1 – 5 (adjustable)		
Max. noise level	72,0 dB(A)		
Operating temperature	5 – 40°C		
Film roll details (max.)	width 500 mm / ext. $\Phi$ 250 mm / core $\Phi$ 76mm (fix) / weight 20 kg / thickness up to 23 microns		

Features	LP	FM	M
4 Automatic modes	•	•	•
9 + 1 individual programs	•	•	•
Pre-Stretch system	•	-	-
Adjustable film tension from control panel	•	•	-
Adjustable tracing wheel	•	•	•
Independent setting of rotation & carriage speeds	•	•	•
Lockable Control Panel	•	•	•
Top-Sheet function	•	•	•
No. of Top- & Bottom windings (independent settable)	•	•	•
Automatic height detection*	•	•	•
Top edge overlap (settable from control-panel)	•	•	•
Adjustable bottom overlap	•	•	•
Auto. film break detection	•	-	-
Energy saving / Auto-Off	•	•	•

\* for wrapping of loads with many open spaces, the height can be programmed instead of using the height detector

### OPTIONS & ACCESSORIES

- Photocell for dark or reflective surfaces
- Film cutting punch (only on LP-carriage)
- Higher Capacity Batteries (87 Ah)
- Carriage for net-film
- Double tracing wheel
- Remote control
- Non-marking wheels
- Wheels for abrasive floor

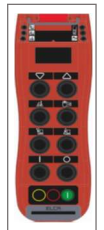

### WORKING FOOTPRINT

Space needed for machine rotation (not including safety area)

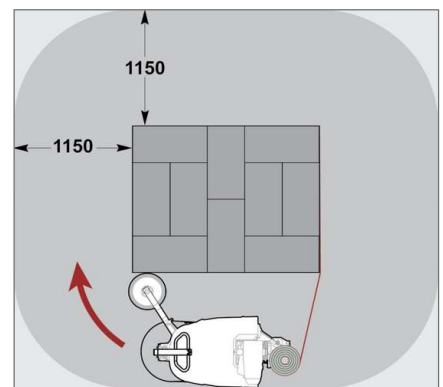

### CONTROL PANEL



- User friendly icons and jog selector for quick parameter set-up
- 9 + 1 customizable program
- Semi-automatic and manual working mode
- Individual Speeds for Up/Down carriage movement
- Separate set-up for top and bottom reinforcement wraps
- Emergency push-button according to regulations

### BATTERY AND SAFETY

Standard AGM batteries allow up to 250 wrapped pallets per single charge\*.

AGM technology, thanks to the absence of acid, makes these batteries the most suitable for mobile applications as they are particularly resistant to vibrations. Charging time is around 8 hours.

BeeWrap<sup>+</sup> safety features include the use of a beacon and klaxon during cycles as well as a safety bumper with sensors which stop the unit immediately if contact is detected.

**Battery Specification**  
2x AGM 12V 57Ah

\* euro-pallet with 1,5 m height, up & down cycle incl. 2 top + 2 bottom wraps, film tension 10 daN

**OPTIONAL:**  
Batteries with higher capacity (87 Ah). Allow to wrap up to 400 pallets with a single charge\*.



### FILM CARRIAGES



### MORE DETAILS

Videos and further information can be found on our website or SIAT YouTube channel.



SAFE • STRONG • SIMPLE

SIAT.com