

DRIVE BELTS	AUTOMATION GRADE	BOX FORMAT	FORMAT SETTING	SEALING TECHNOLOGY
SIDE	SEMI-AUTOMATIC	UNIFORM	MANUAL	PSA TAPES

# NASTRO-SB M

## SEMI-AUTO UNIFORM SIZE CASE SEALER

Nastro-SB M is a semi-automatic case sealing machine with double side drive belts, designed and engineered by SIAT to seal with adhesive tapes both upper and lower sides of uniform size boxes with manual adjustment, from small to very big dimensions, from 500 to 800mm.



### KEY BENEFITS

#### PRODUCTION GUARANTEED

Easy and fast manual box adjustment with simultaneous upper & lower flaps sealing to overcome manual operations, reaching up to 20 box per minute

#### THE POWER OF FLEXIBILITY

Available in different set up and configurations to be able to perfectly process a huge variety of box dimension, covering the market needs.

#### PERFECT BOX SEALING

Dual 75mm side drive belts with the full series of SIAT K taping units available to be installed, from 25 to 75mm width

#### EASY-TO-USE

Fast taping units and tape reels changeover without tools, manually adjustable side belts and electric switch to start operations easy and quick

#### SAFETY FIRST

Pinch points eliminated, central or lateral double emergency buttons, lockable electrical switch and CE compliancy to guarantee ergonomic and safe operations



**Max. production capacity:**  
**Up to 1200\* BPH**

\*Based on the shortest processible box length and provided an optimum continuous box infeed by the operator.

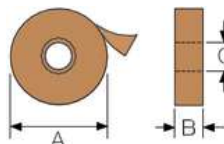

M5 - Machine Weight (kg)	250
M6 - Machine Weight (kg)	260
M8 - Machine Weight (kg)	280

### SPECIFICATIONS

#### Boxes

Nastro-SB M5	Standard Box Version	Low Box Version
Box Min (mm) LxWxH	120 x 150 x 90*	120 x 80 **x 60**
Box Max (mm) LxWxH	∞ x 500 x 500	∞ x 500 x 500
Nastro-SB M6	Standard Box Version	Low Box Version
Box Min (mm) LxWxH	120 x 150 x 90*	120 x 80 **x 60**
Box Max (mm) LxWxH	∞ x 650 x 650	∞ x 650 x 650
Nastro-SB M8	Standard Box Version	Low Box Version
Box Min (mm) LxWxH	120 x 150 x 90*	120 x 80 **x 60**
Box Max (mm) LxWxH	∞ x 800 x 800	∞ x 800 x 800
Box Type	RSC, HSC, FEFCO 0200/0201	
Flute Type	B-C-E	
Min-Max Box Weight (kg)	0,5-32	
* 90 with 30mm leg, 100 with 50mm leg, 120 with 70mm leg		
** Considering the smallest unit in displacement configuration		

#### Machine

Productivity up to (bpm)	20
Based on the shortest processible box length, operator speed, box and tape quality	
Belt Speed (m/min)	26
Operator side	Left - Right
(B) Taping Units	K25 (1"/25mm) - K38 (1,5"/38mm) - K11 (2"/50mm) - K12 (3"/75mm)
Tape Legs (mm)	30 - 50 - 70
Processable Tapes	PVC / OPP / PET / Paper
(A) Tape Reel Max DIA (mm)	410
(C) Inner Tape Core (mm)	76
Air Consumption (NI/Cycle)	-
(BH) Workbench height (mm)	540-800
Power Supply	380/415V 50Hz 3PH+N+PE 220/240V 50Hz 1PH+N+PE*
Pneumatic Supply (bar)	-
Installed Power (kW)	0,26
Power Absorption (Amps)	1,08
M5 - Machine Dimensions LxWxH (mm)	1.100 x 1.085 x 1.315/1.575
M6 - Machine Dimensions LxWxH (mm)	1.100 x 1.240 x 1.460/1.720
M8 - Machine Dimensions LxWxH (mm)	1.100 x 1.390 x 1.575/1.835

\*Other power supplies available upon request



## KEY FEATURES

### Perfect Box Traction

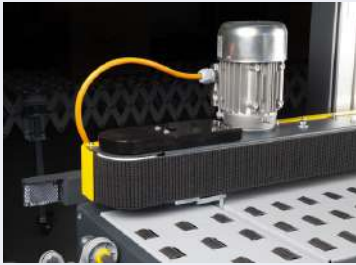

Double screw manually adjustable columns and double screw 75mm side drive belts to guarantee centered and stable box sealing

### Easy to Set Up & Operate



Fast unit changeover, manual height and width adjustment by handles and ON-OFF main electrical switch for an easy and fast start up

### Best-in-class Taping Unit



Equipped with SIAT K Taping Unit, a market benchmark which offers:

- Smooth and consistent tape application
- Fast reel change and threading
- Plug&Play system for fast replacement

### From very small boxes



Low Boxes Verion with displaceable Integrated taping units can enhance the limits allowing to process very small and very narrow boxes

### To very big boxes

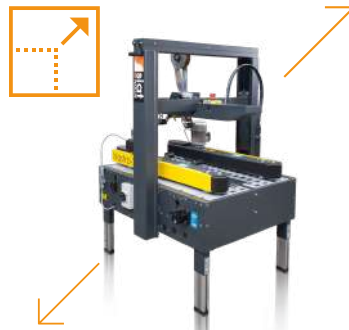

In case of box ranges that exceed 500mm sizes, "king size" set up available to handle bigger cartons sizes

### Automation Upgrade



Can be equipped with the Passive 3-Flaps Folder, supporting productivity and improving the ergonomcy in the operator sealing processes

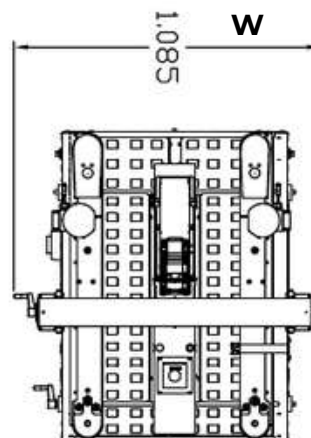
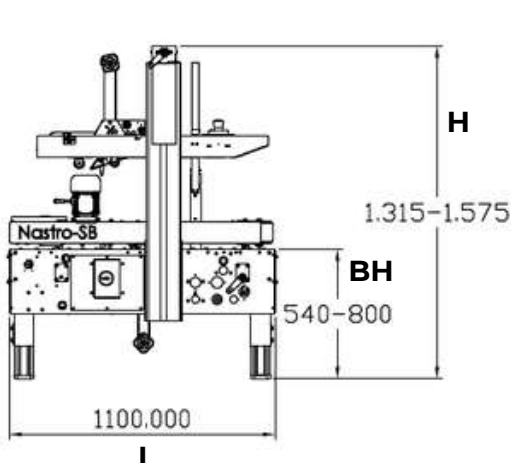

## OPTIONALS

Safety Fences
Prolonged Motorization
Wheels <sup>1</sup>
Higher Legs <sup>2</sup>
Lower Legs <sup>3</sup>
Passive 3-flap folder
Conveyors: <u>GTL- GTR</u> (extendable conveyors), <u>RG</u> (roller conveyor)
<sup>1</sup> Workbench height becoming 650 - 910
<sup>2</sup> Workbench height becoming 760 - 1020
<sup>3</sup> Workbench height becoming 440 - 700

